

# 14-760: ADV. REAL-WORLD NETWORKS

---

LEGACY MOBLE NETWORKS \* LECTURE 8 \* SPRING 2020

This lecture is adapted from Prof. Dantu's CSE 5520/4520 (Fall 2018) class at University of North Texas:

- [http://www.cse.unt.edu/~rdantu/FALL\\_2018\\_WIRELESS\\_NETWORKS/2G\\_3G\\_4G\\_Tutorial.ppt](http://www.cse.unt.edu/~rdantu/FALL_2018_WIRELESS_NETWORKS/2G_3G_4G_Tutorial.ppt)

These slides are his, lightly restyled

# CELLULAR NETWORK BASICS

- There are many types of cellular services; before delving into details, focus on basics (helps navigate the “acronym soup”)
- Cellular network/telephony is a *radio*-based technology; radio waves are electromagnetic waves that *antennas* propagate
- Most signals are in the 850 MHz, 900 MHz, 1800 MHz, and 1900 MHz frequency bands

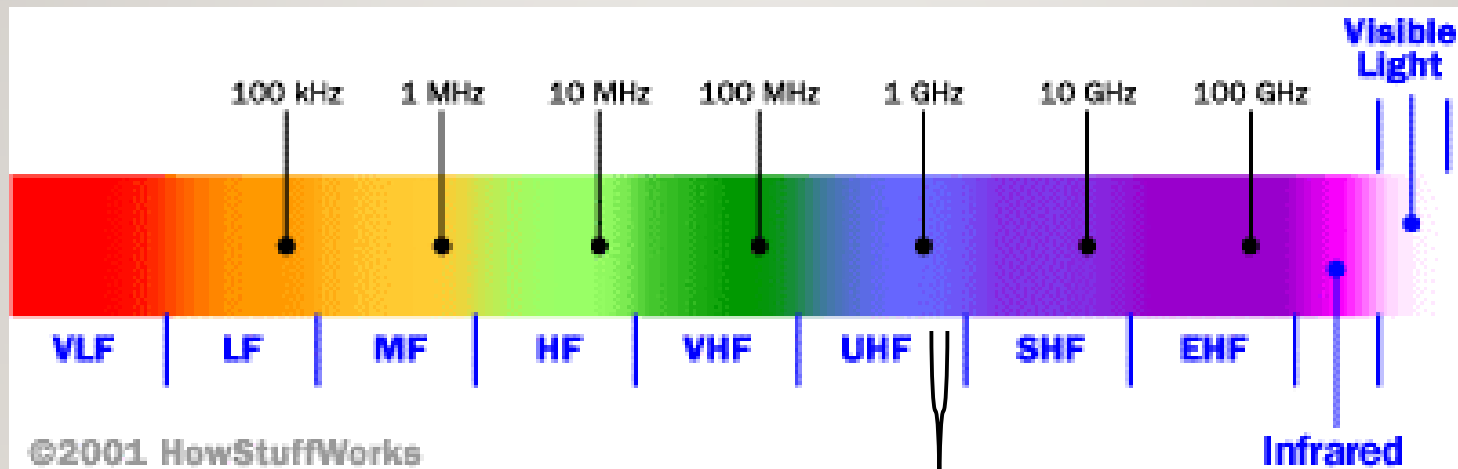

Cell phones operate in this frequency range (note the *logarithmic* scale)

# CELLULAR NETWORK

---

- Base stations transmit to and receive from mobiles at the assigned spectrum
  - Multiple base stations use the same spectrum (spectral reuse)
- The service area of each base station is called a cell
- Each mobile terminal is typically served by the 'closest' base stations
  - Handoff when terminals move

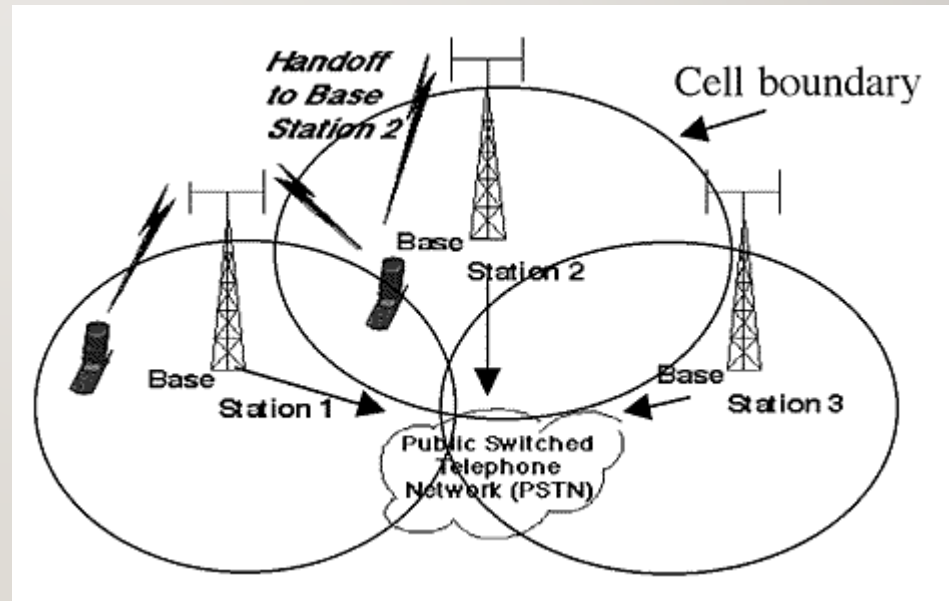

# CELLULAR NETWORK GENERATIONS

---

- It is useful to think of cellular Network/telephony in terms of *generations*:
  - 0G: Briefcase-size mobile radio telephones
  - 1G: *Analog* cellular telephony
  - 2G: *Digital* cellular telephony
  - 3G: *High-speed* digital cellular telephony (including *video telephony*)
  - 4G: IP-based “anytime, anywhere” voice, data, and multimedia telephony at *faster* data rates than 3G

# EVOLUTION OF CELLULAR NETWORKS

---

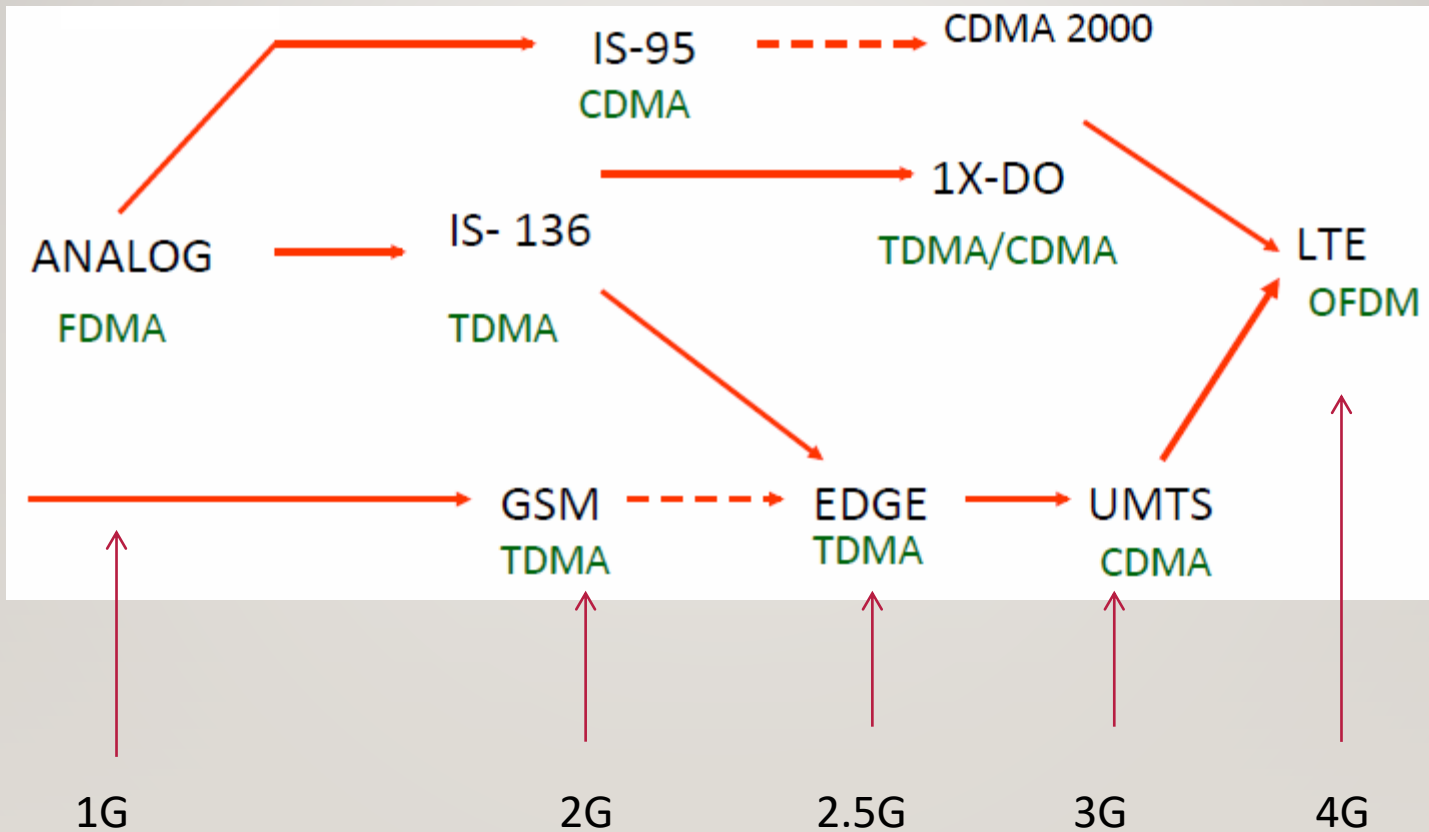

# THE MULTIPLE ACCESS PROBLEM

---

- The base stations need to serve many mobile terminals at the same time (both downlink and uplink)
- All mobiles in the cell need to transmit to the base station
- Interference among different senders and receivers
- So we need multiple access scheme

# MULTIPLE ACCESS SCHEMES

---

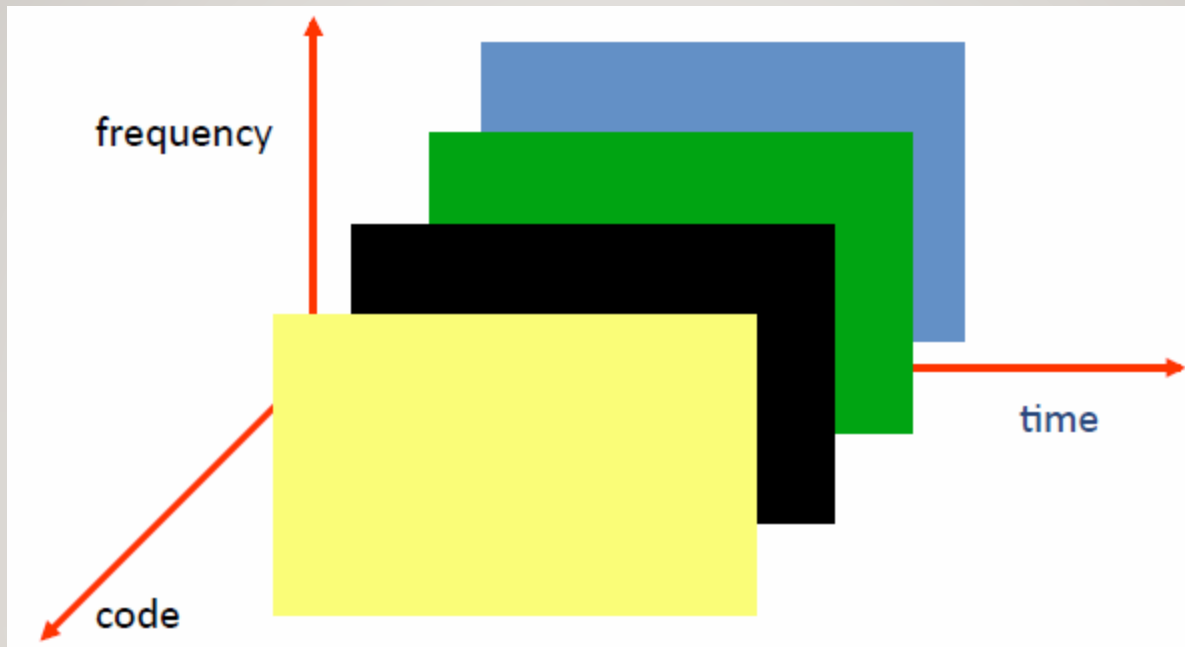

## 3 orthogonal Schemes:

- Frequency Division Multiple Access (FDMA)
- Time Division Multiple Access (TDMA)
- Code Division Multiple Access (CDMA)

# FREQUENCY DIVISION MULTIPLE ACCESS

---

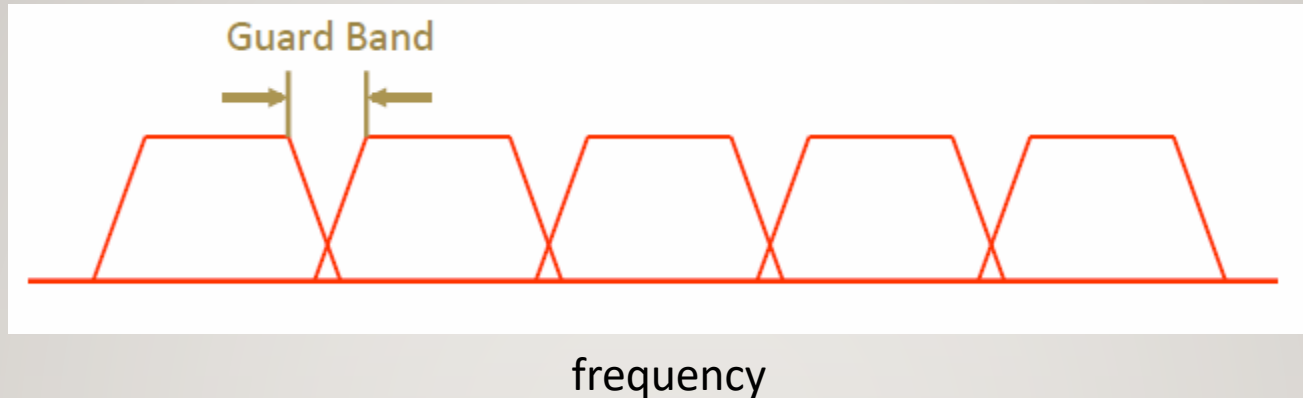

- Each mobile is assigned a separate frequency channel for the duration of the call
- Sufficient guard band is required to prevent adjacent channel interference
- Usually, mobile terminals will have one downlink frequency band and one uplink frequency band
- Different cellular network protocols use different frequencies
- Frequency is a precious and scarce resource. We are running out of it



# TIME DIVISION MULTIPLE ACCESS

---

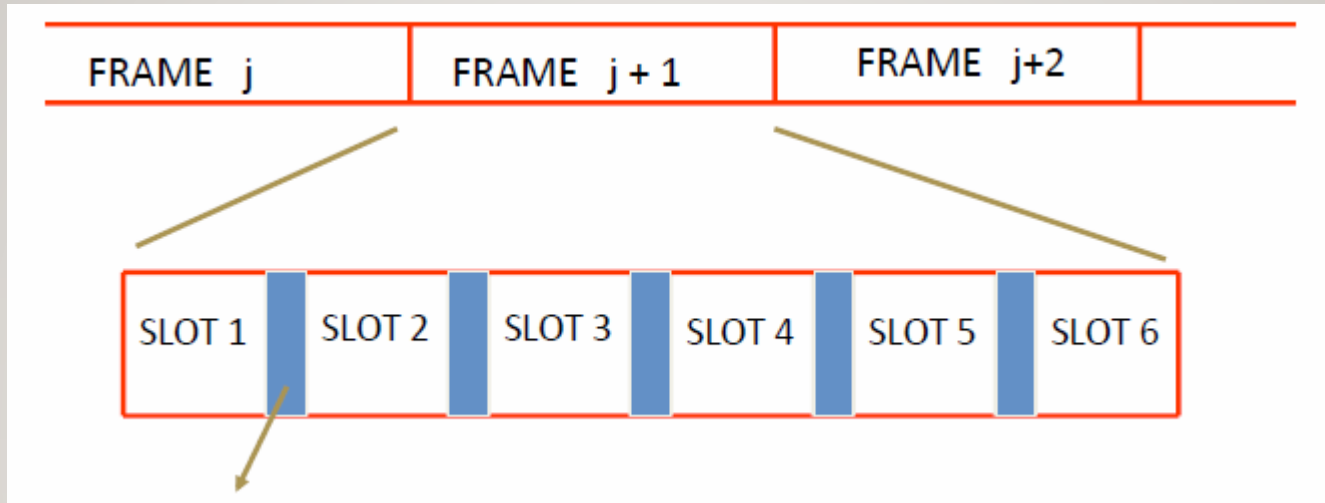

Guard time – signal transmitted by mobile terminals at different locations do not arrive at the base station at the same time

- Time is divided into slots and only one mobile terminal transmits during each slot
  - Like during the lecture, only one can talk, but others may take the floor in turn
- Each user is given a specific slot. No competition in cellular network
  - Unlike Carrier Sensing Multiple Access (CSMA) in WiFi

# CODE DIVISION MULTIPLE ACCESS

---

- Use of orthogonal codes to separate different transmissions
- Each symbol of bit is transmitted as a larger number of bits using the user specific code – Spreading
  - Bandwidth occupied by the signal is much larger than the information transmission rate
  - But all users use the same frequency band together

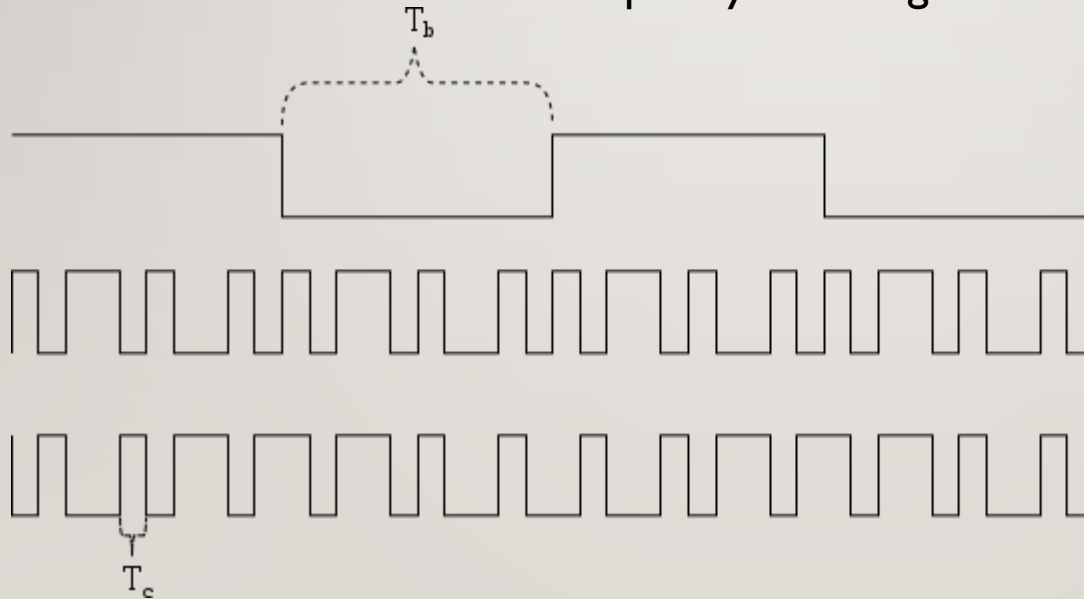

Orthogonal among users

Data Signal

Pseudorandom Code

Transmitted signal:  
Data Signal XOR with  
the Pseudorandom

# CODE DIVISION MULTIPLE ACCESS (CDMA)

---

## (2G)

- Each unit is given a unique id known as a *chip sequence*.
- All chip sequences are the same length
- All chip sequences have the same number of 0s as 1s
- A sender sends a 1-bit by transmitting its chip sequence
- A sender sends a 0-bit by transmitting the 1s complement (flip each bit) of its chip sequence
- Collision can occur, but will not destroy data

# CDMA, cont.

---

- Since each chip sequence must be of the same size and have as many 0s as 1s, the dot-product of two chip sequences is 0, unless they are the same, in which case it is 1.
- When multiple stations transmit concurrently, their signals add linearly
- To ensure that their power is the same, they transmit with the inverse power of the base station's signal strength
- Sender and receiver must be synchronized for the linear combination to work. This is accomplished by training the receiver to the sender using a known bit sequence.

Kesden-added slide.



# CDMA, cont

---

$$\mathbf{S} \cdot \mathbf{T} = \frac{1}{m} \sum_{i=1}^m S_i T_i = 0$$

$$\mathbf{S} \cdot \mathbf{S} = \frac{1}{m} \sum_{i=1}^m S_i S_i = \frac{1}{m} \sum_{i=1}^m S_i^2 = \frac{1}{m} \sum_{i=1}^m (+/-1)^2 = 1$$

If we represent 0s and 1s as  $-1$ s and  $1$ s, the dot product of a chip sequence and itself is 1, whereas the dot product of a chip sequence

And any other chip sequence is 0.

# CDMA, CONT.

---

- Recall that collision will result in the linear combination of chip sequences.
- The dot product of this linear combination of chip sequences and the sender's chip sequence will result in a 1 if the sender sent a 1 or a  $-1$ , otherwise.
- The other sequences “balance out” and become
  - 0. The interesting chip sequence is multiplied by itself, or the compliment of itself, yielding 1 or  $-1$ .
- Consider 0101 vs 1010 vs 1100 vs 0011 vs 0110
  - vs 1001.

# 2G(GSM)

---

# GSM

---

- Abbreviation for Global System for Mobile Communications
- Concurrent development in USA and Europe in the 1980's
- The European system was called GSM and deployed in the early 1990's



# GSM SERVICES

---

- Voice, 3.1 kHz
- Short Message Service (SMS)
  - 1985 GSM standard that allows messages of at most 160 chars. (incl. spaces) to be sent between handsets and other stations
  - At one point 2.4 *billion* people use it; multi-billion \$ industry
    - Long term trend favors integrated and richer services (Kesden)
- General Packet Radio Service (GPRS)
  - GSM upgrade that provides IP-based packet data transmission up to 114 kbps
  - Users can “simultaneously” make calls and send data
  - GPRS provides “always on” Internet access and the Multimedia Messaging Service (MMS) whereby users can send rich text, audio, video messages to each other
  - Performance degrades as number of users increase
  - GPRS is an example of 2.5G telephony – 2G service similar to 3G

# GSM CHANNELS

---

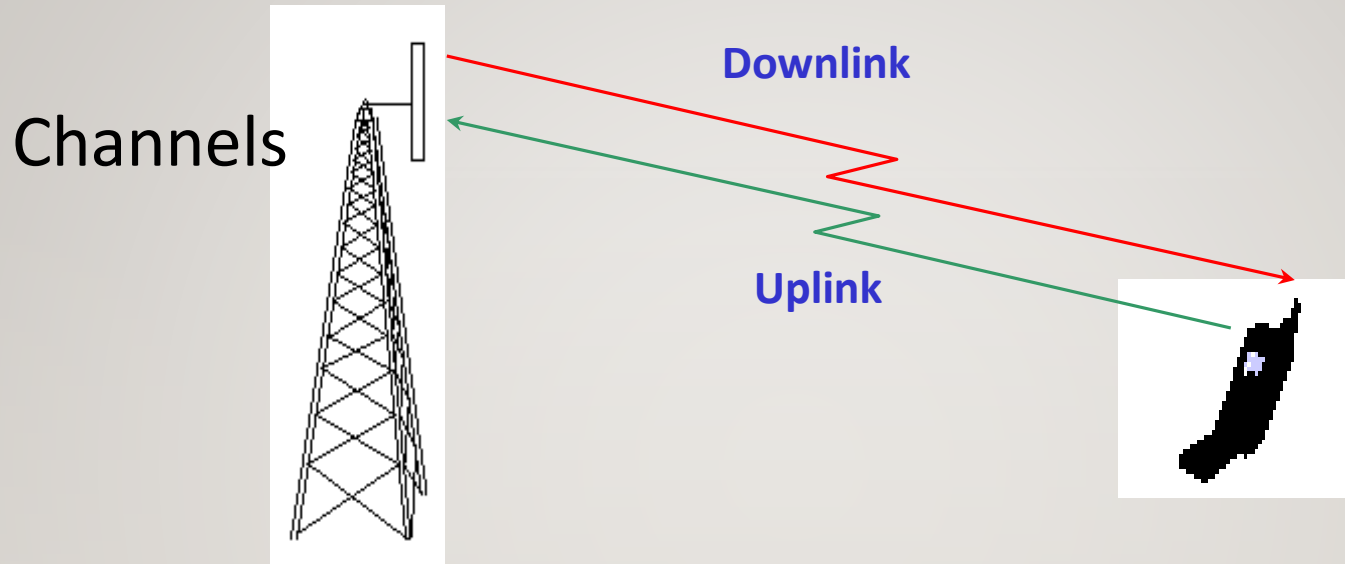

- Physical Channel: Each timeslot on a carrier is referred to as a physical channel
- Logical Channel: Variety of information is transmitted between the MS and BTS.
  - MS = Mobile Station, BTS=Base Transceiver Station
- Different types of logical channels:
  - Traffic channel
  - Control Channel

# GSM FREQUENCIES

---

- Originally designed on 900MHz range
  - Now also available on 800MHz, 1800MHz and 1900 MHz ranges.
- Separate Uplink and Downlink frequencies
  - One example channel on the 1800 MHz frequency band, where RF carriers are space every 200 MHz

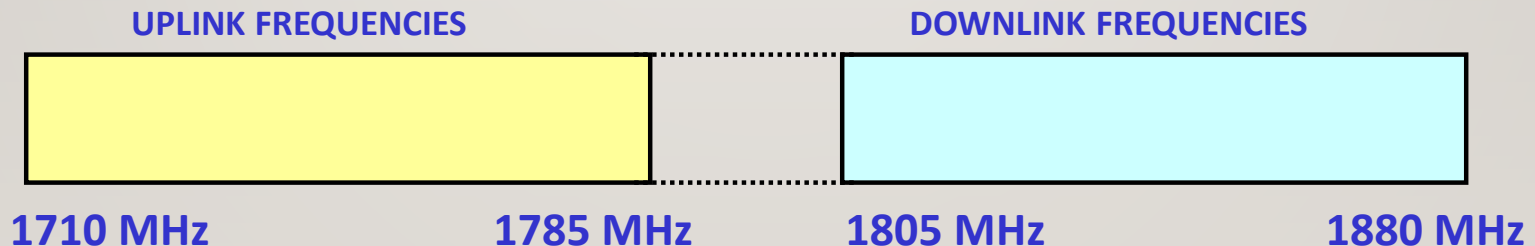

UPLINK AND DOWNLINK FREQUENCY SEPARATED BY 95MHZ

# GSM ARCHITECTURE

---

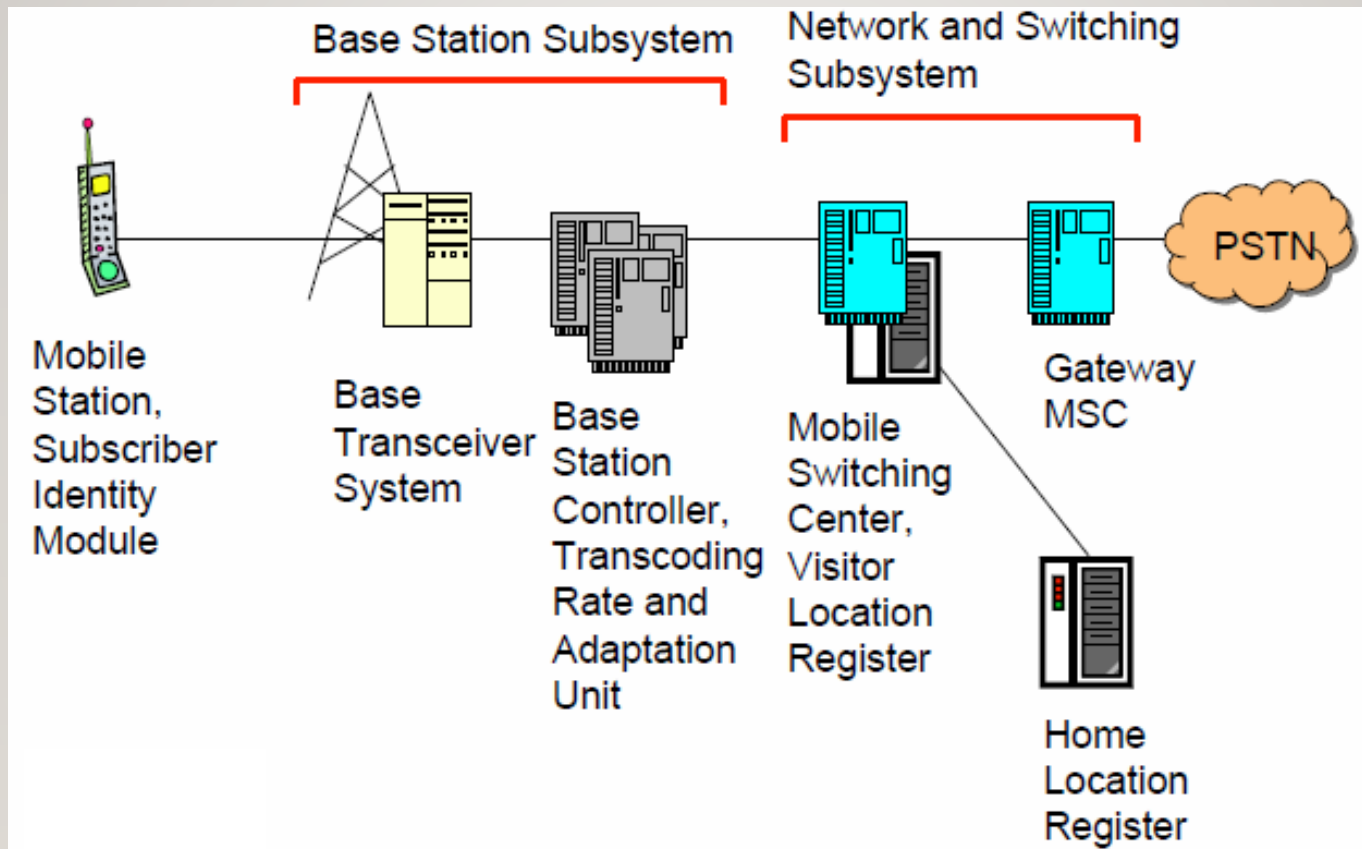

# MOBILE STATION (MS)

---

- MS is the user's handset and has two parts
  - Mobile Equipment
    - Radio equipment
    - User interface
    - Processing capability and memory required for various tasks
      - Call signalling
      - Encryption
      - SMS
    - Equipment IMEI number
  - Subscriber Identity Module

# SUBSCRIBER IDENTITY MODULE ("SIM CARD")

---

- A small smart card
- Encryption codes needed to identify the subscriber
- Subscriber IMSI number
- Subscriber's own information (telephone directory)
- Third party applications (banking etc.)
- Can also be used in other systems besides GSM, e.g., some WLAN access points accept SIM based user authentication



# BASE STATION SUBSYSTEM

---

- Transcoding Rate and Adaptation Unit (TRAU)
  - Performs coding between the 64kbps PCM coding used in the backbone network and the 13 kbps coding used for the Mobile Station (MS)
- Base Station Controller (BSC)
  - Controls the channel (time slot) allocation implemented by the BTSes
  - Manages the handovers within BSS area
  - Knows which mobile stations are within the cell and informs the MSC/VLR about this
- Base Transceiver System (BTS)
  - Controls several transmitters
  - Each transmitter has 8 time slots, some used for signaling, on a specific frequency

# NETWORK AND SWITCHING SUBSYSTEM

---

- The backbone of a GSM network is a telephone network with additional cellular network capabilities
- Mobile Switching Center (MSC)
  - An typical telephony exchange (ISDN exchange) which supports mobile communications
  - Visitor Location Register (VLR)
    - A database, part of the MSC
    - Contains the location of the active Mobile Stations
- Gateway Mobile Switching Center (GMSC)
  - Links the system to PSTN and other operators
- Home Location Register (HLR)
  - Contain subscriber information, including authentication information in Authentication Center (AuC)
- Equipment Identity Register (EIR)
  - International Mobile Station Equipment Identity (IMEI) codes for e.g., blacklisting stolen phones



# HOME LOCATION REGISTER

---

- One database per operator
- Contains all the permanent subscriber information
  - MSISDN (Mobile Subscriber ISDN number) is the telephone number of the subscriber
  - International Mobile Subscriber Identity (IMSI) is a 15 digit code used to identify the subscriber
    - It incorporates a country code and operator code
  - IMSI code is used to link the MSISDN number to the subscriber's SIM (Subscriber Identity Module)
  - Charging information
  - Services available to the customer
- Also the subscriber's present Location Area Code, which refers to the MSC, which can connect to the MS.

# OTHER SYSTEMS

---

- Operations Support System
  - The management network for the whole GSM network
  - Usually vendor dependent
  - Very loosely specified in the GSM standards
- Value added services
  - Voice mail
  - Call forwarding
  - Group calls
- Short Message Service Center
  - Stores and forwards the SMS messages
  - Like an E-mail server
  - Required to operate the SMS services

# LOCATION UPDATES

---

- The cells overlap and usually a mobile station can 'see' several transceivers (BTSes)
- The MS monitors the identifier for the BSC controlling the cells
  - BSC = Base Station Controller
- When the mobile station reaches a new BSC's area, it requests a location update
- The update is forwarded to the MSC, entered into the VLR, the old BSC is notified and an acknowledgement is passed back

# HANDOFF (HANDOVER)

- When a call is in process, the changes in location need special processing
- Within a BSS, the BSC, which knows the current radio link configuration (including feedbacks from the MS), prepares an available channel in the new BTS
- The MS is told to switch over to the new BTS
- This is called a hard handoff
  - In a soft handoff, the MS is connected to two BTSes simultaneously

# ROAMING

---

- When a MS enters another operators network, it can be allowed to use the services of this operator
  - Operator to operator agreements and contracts
  - Higher billing
- The MS is identified by the information in the SIM card and the identification request is forwarded to the home operator
  - The home HLR is updated to reflect the MS's current location

# 3G, 3.5G AND 4G (LTE)

---



# 3G OVERVIEW

- 3G is created by ITU-T and is called IMT-2000

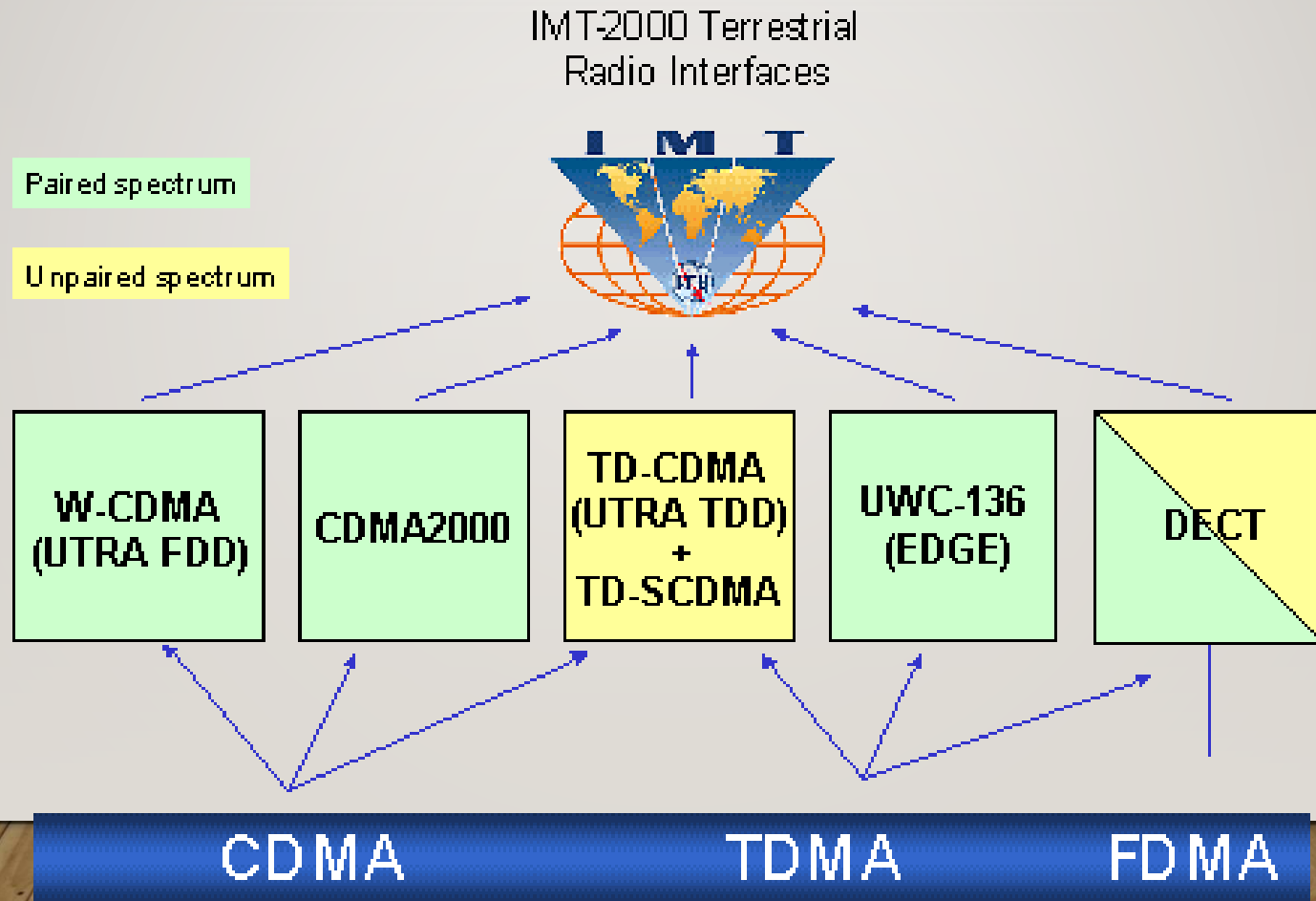

# EVOLUTION FROM 2G

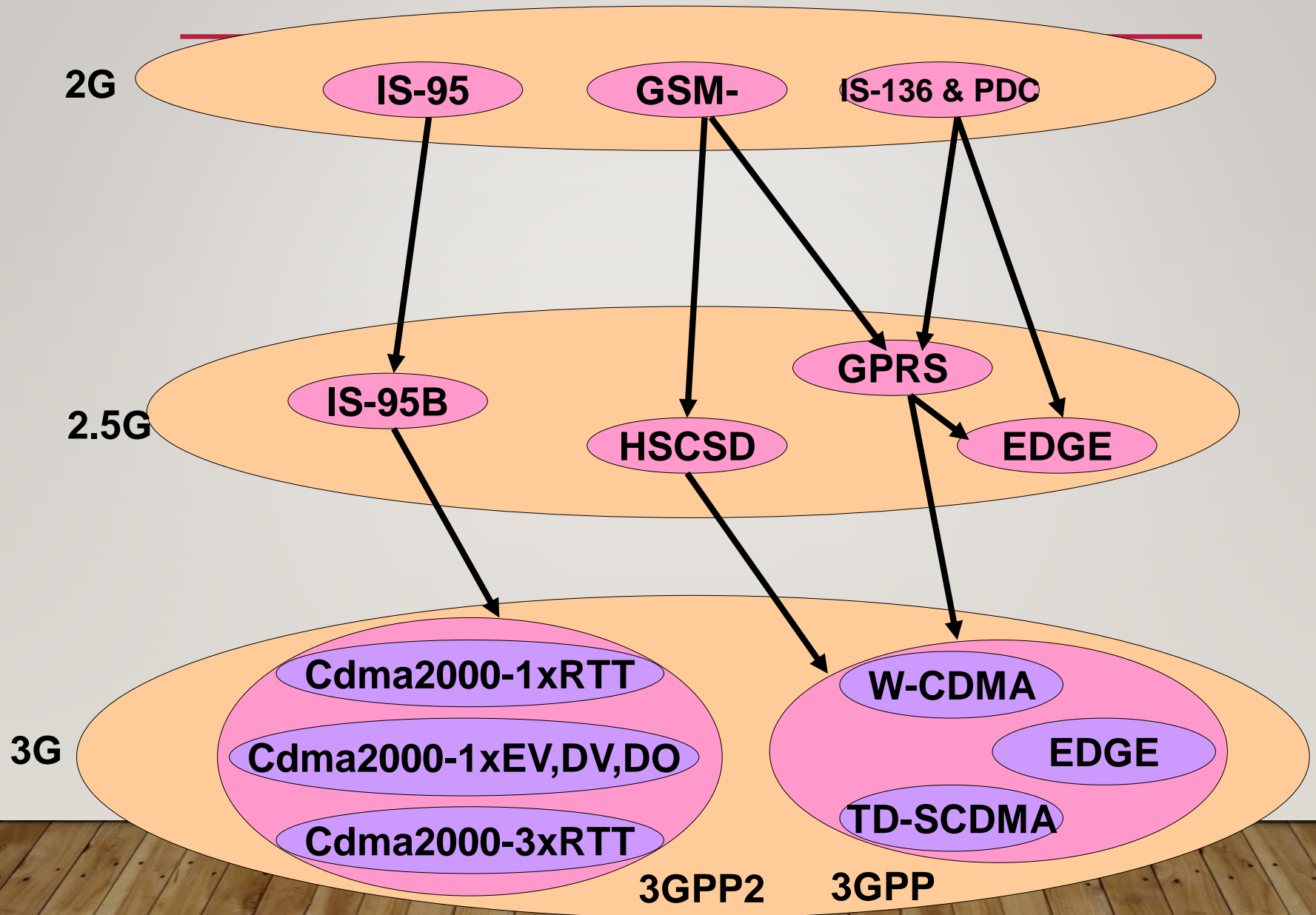



# SERVICE ROADMAP

Improved performance, decreasing cost of delivery



A number of mobile services are bearer independent in nature

3G-specific services take advantage of higher bandwidth and/or real-time QoS

Broadband in wide area

Video sharing  
Video telephony  
Real-time IP multimedia and games  
Multicasting

Multitasking  
WEB browsing  
Corporate data access  
Streaming audio/video

Voice & SMS

MMS picture / video  
xHTML browsing  
Application downloading  
E-mail  
Presence/location  
Push-to-talk

GSM  
9.6  
kbps

GPRS  
171  
kbps

EGPRS  
473  
kbps

WCDMA  
2  
Mbps

HSDPA  
1-10  
Mbps

CDMA  
2000 1x

CDMA  
2000-  
EVDO

CDMA  
2000-  
EVDV

Typical average bit rates  
(peak rates higher)

# GSM EVOLUTION TO 3G

## High Speed Circuit Switched Data

Dedicate up to 4 timeslots for data connection ~ 50 kbps  
Good for real-time applications c.w. GPRS  
Inefficient -> ties up resources, even when nothing sent  
Not as popular as GPRS (many skipping HSCSD)

## Enhanced Data Rates for Global Evolution

Uses 8PSK modulation  
3x improvement in data rate on short distances  
Can fall back to GMSK for greater distances  
Combine with GPRS (EGPRS) ~ 384 kbps  
Can also be combined with HSCSD

**GSM**  
9.6kbps (one timeslot)  
GSM Data  
Also called CSD

**HSCSD**

**WCDMA**

**GSM**

**GPRS**

**EDGE**

## General Packet Radio Services

Data rates up to ~ 115 kbps  
Max: 8 timeslots used as any one time  
Packet switched; resources not tied up all the time  
Contention based. Efficient, but variable delays  
GSM / GPRS core network re-used by WCDMA (3G)

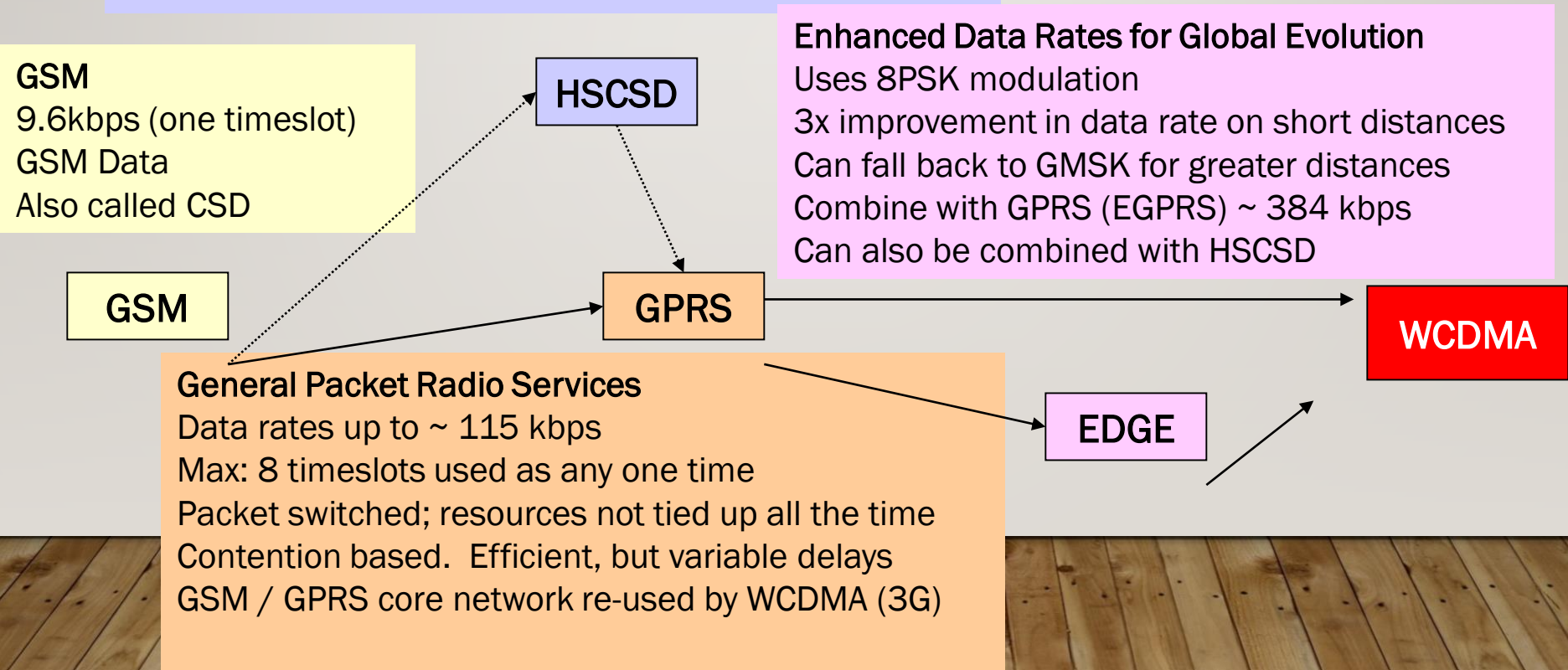

# UMTS

---

- Universal Mobile Telecommunications System (UMTS)
- UMTS is an upgrade from GSM via GPRS or EDGE
- The standardization work for UMTS is carried out by Third Generation Partnership Project (3GPP)
- Data rates of UMTS are:
  - 144 kbps for rural
  - 384 kbps for urban outdoor
  - 2048 kbps for indoor and low range outdoor
- Virtual Home Environment (VHE)

# UMTS FREQUENCY SPECTRUM

---

- UMTS Band
  - 1900-2025 MHz and 2110-2200 MHz for 3G transmission
  - In the US, 1710–1755 MHz and 2110–2155 MHz will be used instead, as the 1900 MHz band was already used.

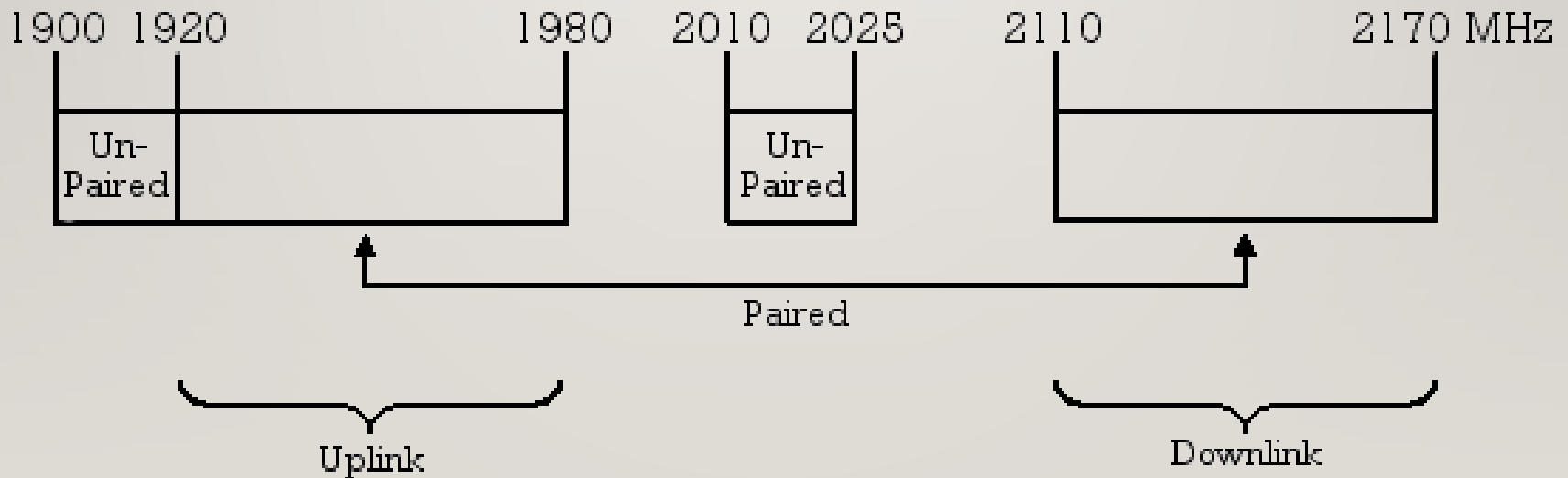

# UMTS ARCHITECTURE

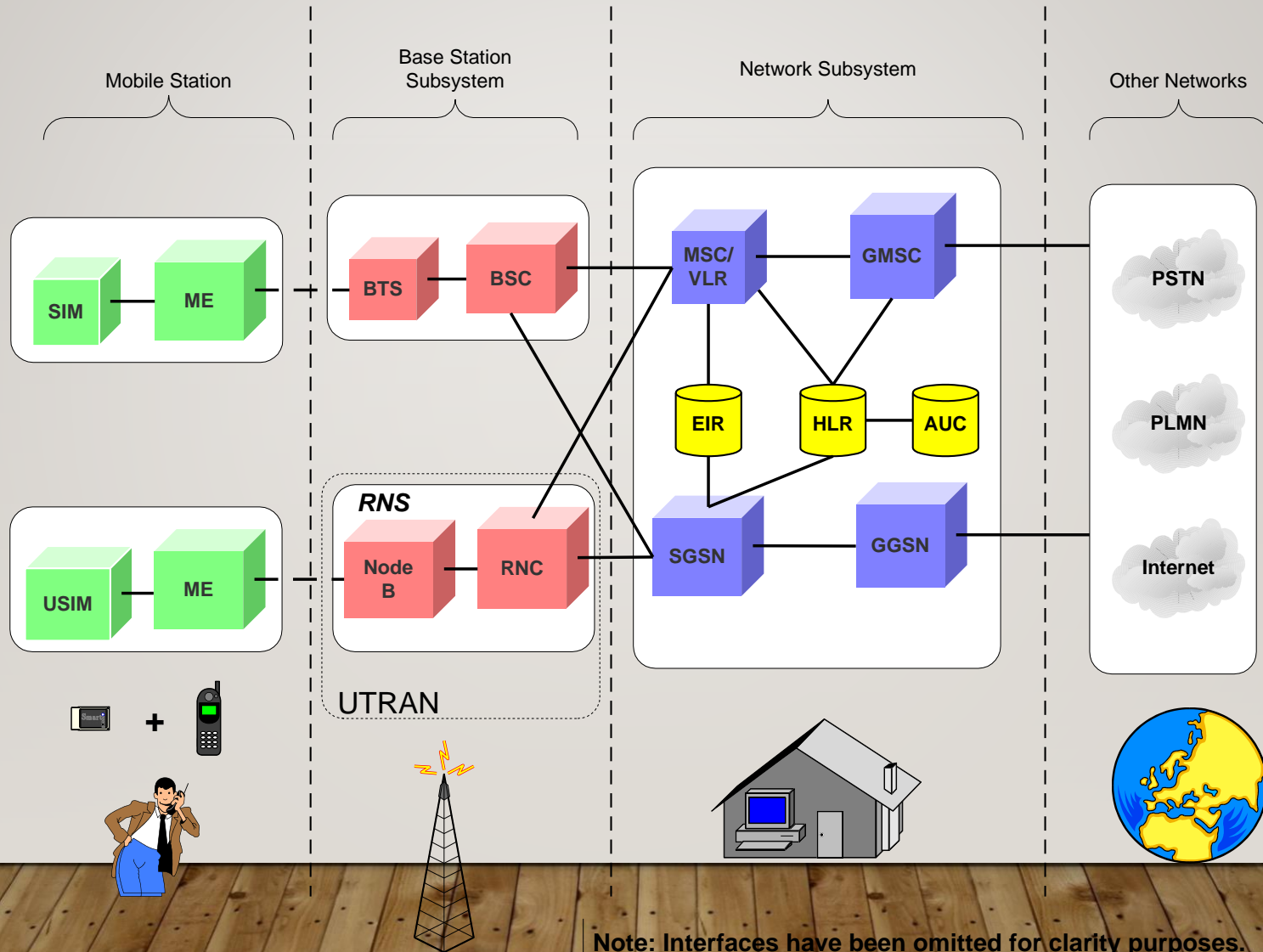

# UMTS NETWORK ARCHITECTURE

---

UMTS network architecture consists of three domains

- Core Network (CN): Provide switching, routing and transit for user traffic
- UMTS Terrestrial Radio Access Network (UTRAN): Provides the air interface access method for user equipment.
- User Equipment (UE): Terminals work as air interface counterpart for base stations. The various identities are: IMSI, TMSI, P-TMSI, TLLI, MSISDN, IMEI, IMEISV

# 3.5G (HSPA)

---

High Speed Packet Access (HSPA) is an amalgamation of two mobile telephony protocols, High Speed Downlink Packet Access (HSDPA) and High Speed Uplink Packet Access (HSUPA), that extends and improves the performance of existing WCDMA protocols

3.5G introduces many new features that will enhance the UMTS technology in future. 1xEV-DV already supports most of the features that will be provided in 3.5G. These include:

- Adaptive Modulation and Coding
- Fast Scheduling
- Backward compatibility with 3G
- Enhanced Air Interface

# 4G (LTE)

---

- LTE stands for Long Term Evolution
- Next Generation mobile broadband technology
- Promises data transfer rates of 100 Mbps
- Based on UMTS 3G technology
- Optimized for All-IP traffic



# ADVANTAGES OF LTE

---

- ▶ High network throughput
- ▶ Low latency
- ▶ Plug & Play architecture
- ▶ Low Operating Costs
- ▶ All-IP network
- ▶ Simplified upgrade path from 3G networks

*for Network Operators*

- ▶ Faster data downloads/uploads
- ▶ Improved response for applications
- ▶ Improved end-user experience

*for End Users*

# COMPARISON OF LTE SPEED

---

## 2G – 4G Data download rates

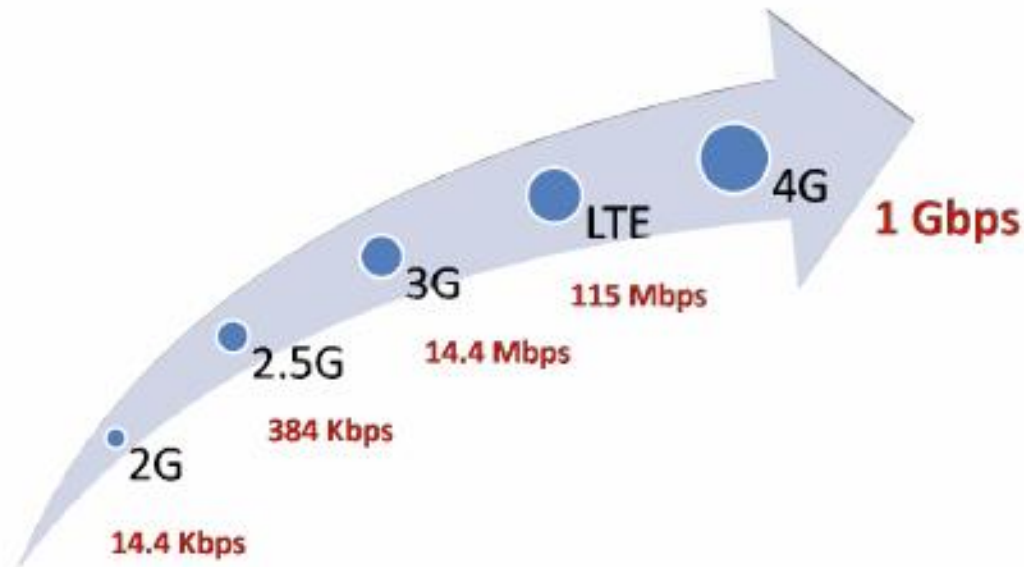

- 2.5G speed is based on the maximum offered by EDGE
- 3G speed is based on the maximum offered by HSDPA

# MAJOR LTE RADIO TECHNOLOGIES

---

- Uses Orthogonal Frequency Division Multiplexing (OFDM) for downlink
- Uses Single Carrier Frequency Division Multiple Access (SC-FDMA) for uplink
- Uses Multi-input Multi-output(MIMO) for enhanced throughput
- Reduced power consumption
- Higher RF power amplifier efficiency (less battery power used by handsets)

# LTE ARCHITECTURE

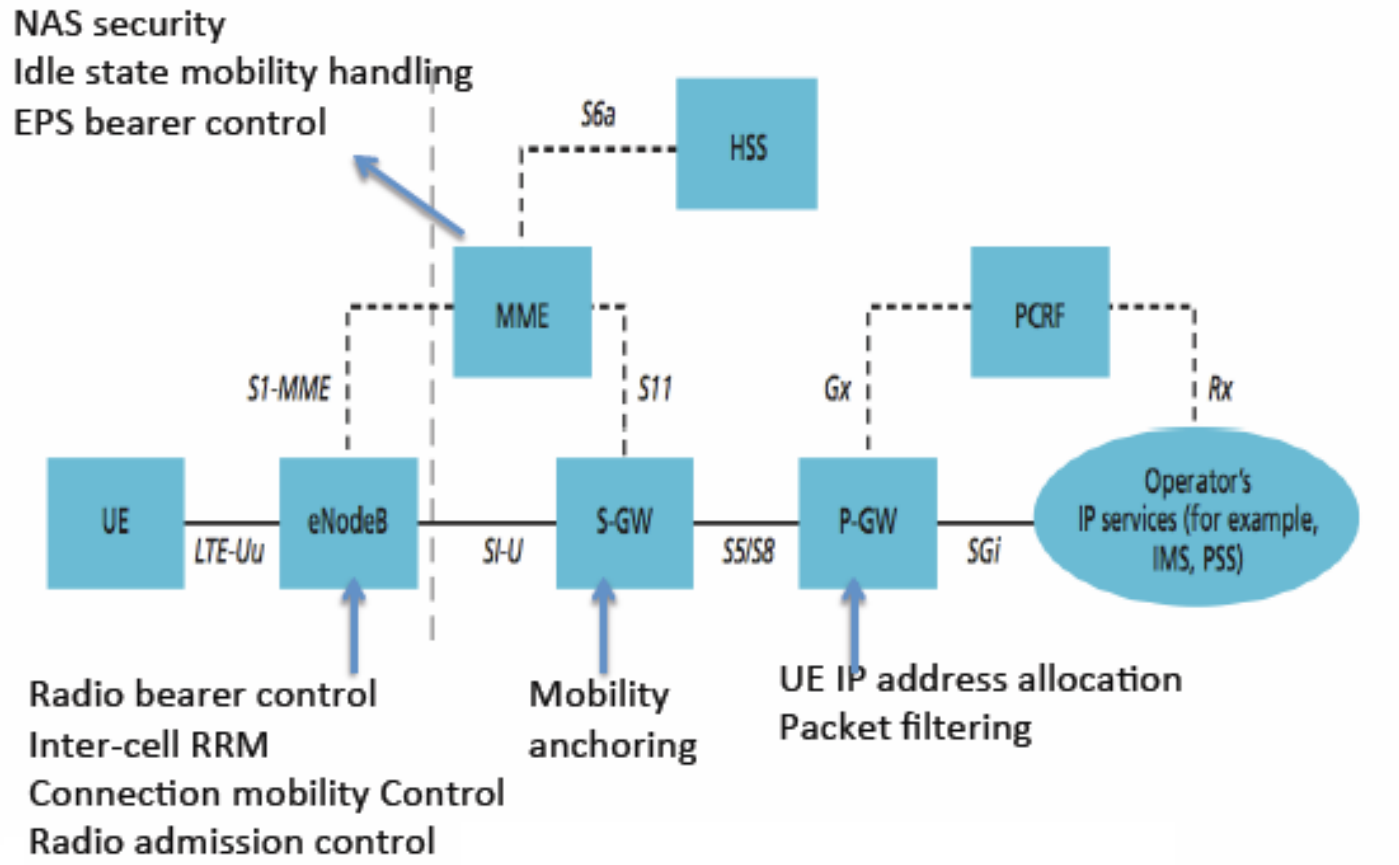

# LTE VS UMTS

- Functional changes compared to the current UMTS architecture

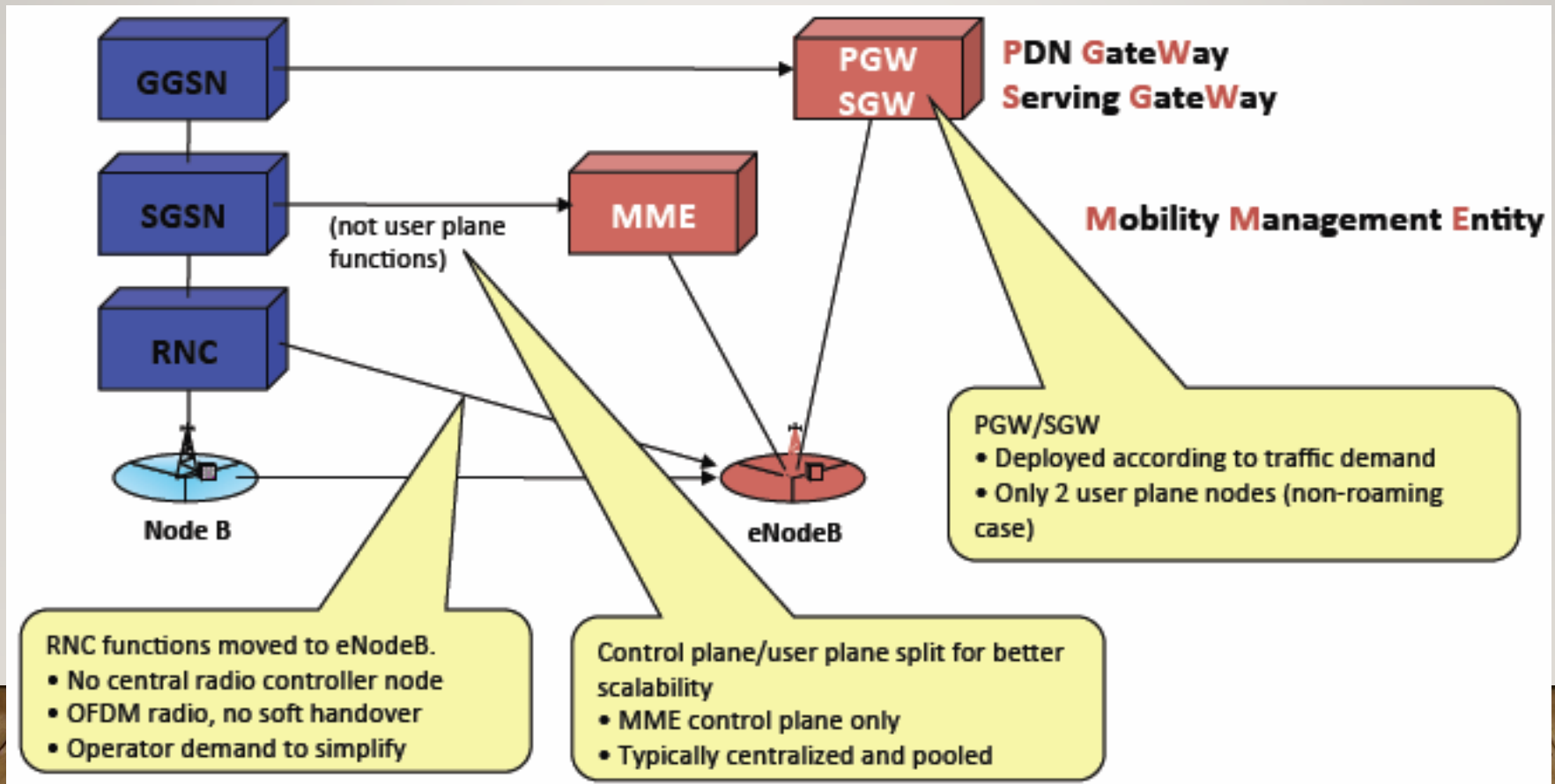

# **CASE STUDY MOBILITY: A DOUBLE-EDGED SWORD FOR HSPA NETWORKS**

---

*Fung Po Tso, City University of Hong Kong  
Jin Teng, Ohio State University  
Weijia Jia, City University of Hong Kong  
Dong Xuan, Ohio State University*

***ACM Mobihoc'10***

# CONTEXT

MobiHoc '10

---



Evolved hardware technologies  
+  
Improved network bandwidth  
=  
Entertainment apps on mobile

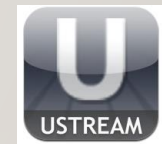

# CONTEXT

MobiHoc '10

---

When you are **NOT** mobile, you use





# CONTEXT

MobiHoc '10

---

When you are **mobile**, you use



# CONTEXT

MobiHoc '10



**Millions** of passengers per day!

# CONTEXT

MobiHoc '10

HSPA Node B



HSPA Node B



Can HSPA provide the same level of service to mobile users on public transport?



pictures' source: Wikipedia

# OUTLINE

MobiHoc '10

---

- Measurement Methodology
- General Impact of Mobility
- Mobility Impact on Bandwidth Sharing
- Mobility Impact in Transitional Region
- Conclusion

# MEASUREMENT ROUTES

MobiHoc '10



Type	Average Speed	Highest Speed	Characteristics
Trains	40 kmh	100 kmh	Surface ground
Subways	30 kmh	80 kmh	Underground
Self-driving Vehicles & Buses	50 & 30 kmh	80 kmh	Surface ground
Ferries	80 kmh	90 kmh	Sea, Surface ground

# MEASUREMENT ROUTE

MobiHoc '10

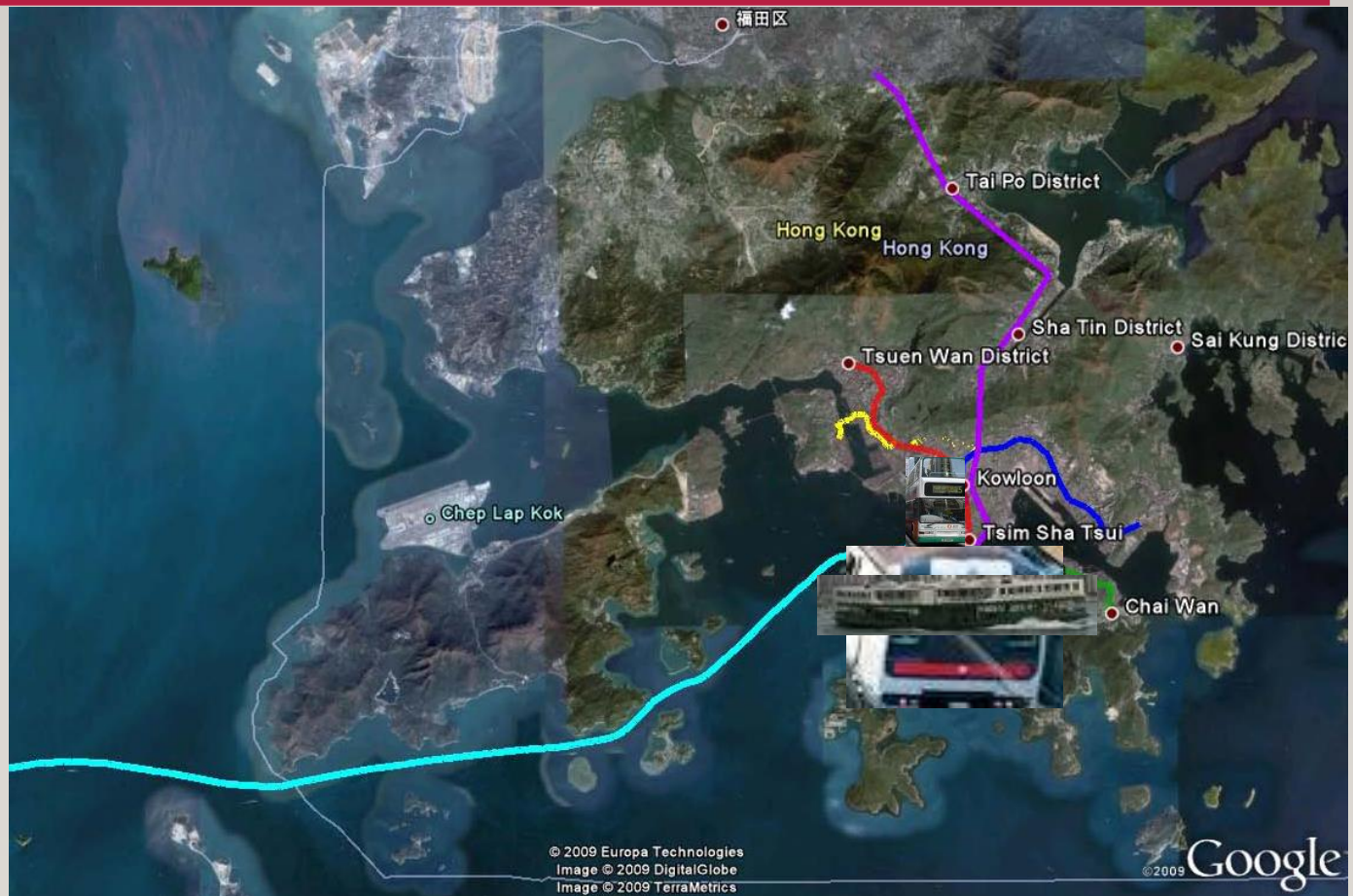

Over **100** km in **3** months

# MEASUREMENT SETUP

MobiHoc '10

- Two Servers:
  - Lab & Data Center
- Three types of evaluations:
  - download only; upload only; simultaneous download & upload.

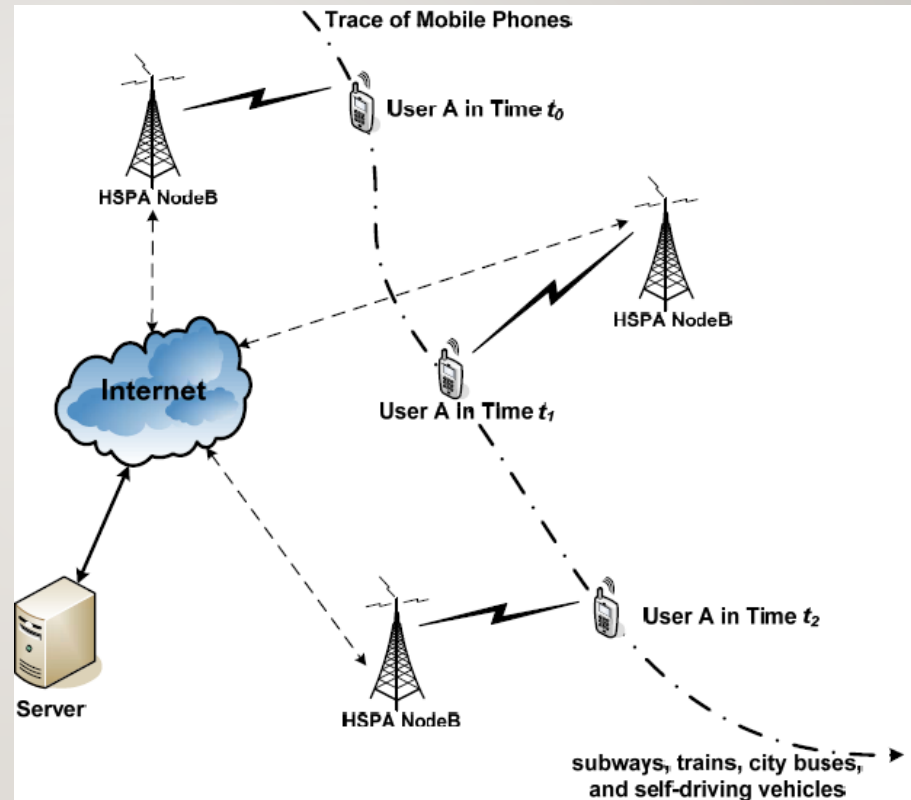

# GENERAL IMPACT OF MOBILITY

MobiHoc '10

- A large spread of HSDPA bit rates and signal quality

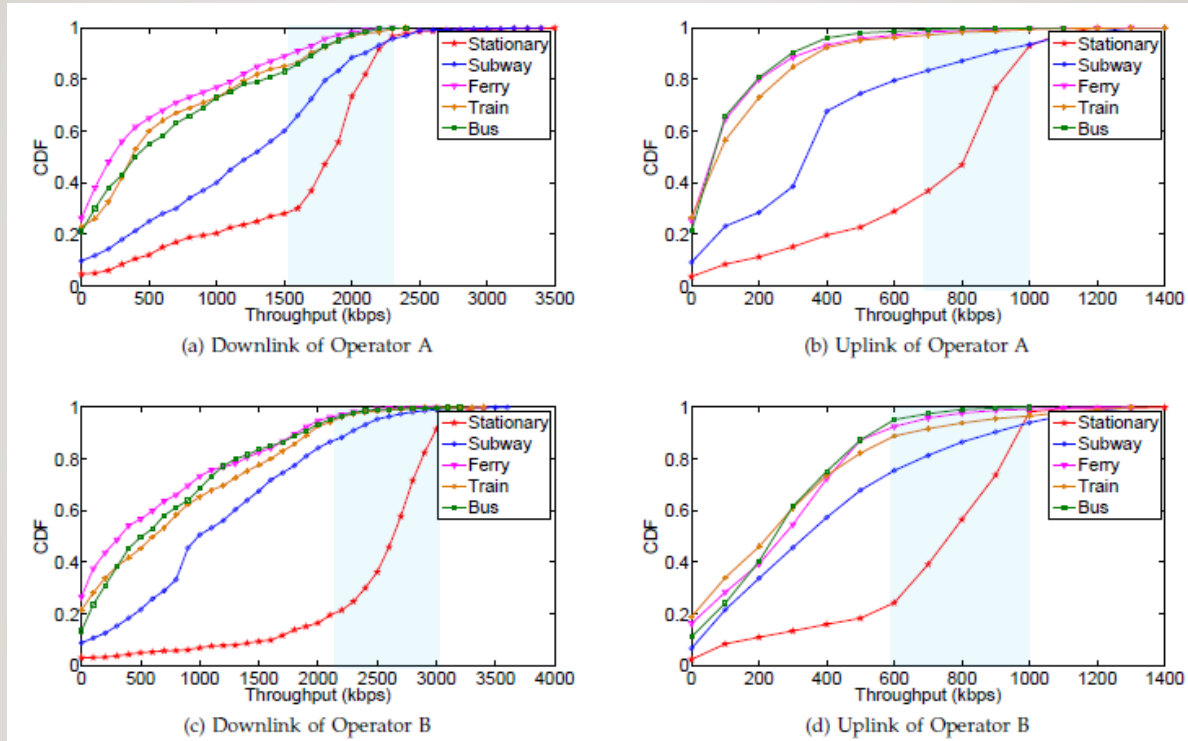



# CONTEXT

MobiHoc '10

---

*Common View: Mobility is irrelevant, if not detrimental, to the fairness in HSPA bandwidth sharing among users*

Observation: The bandwidth sharing practice in stationary HSPA environments is **unfair**. In contrast, mobility surprisingly improves fairness of bandwidth sharing (**fairer**).

# BANDWIDTH SHARING AMONG USERS

MobiHoc '10

- Mobility actually improves the fairness of bandwidth sharing among users

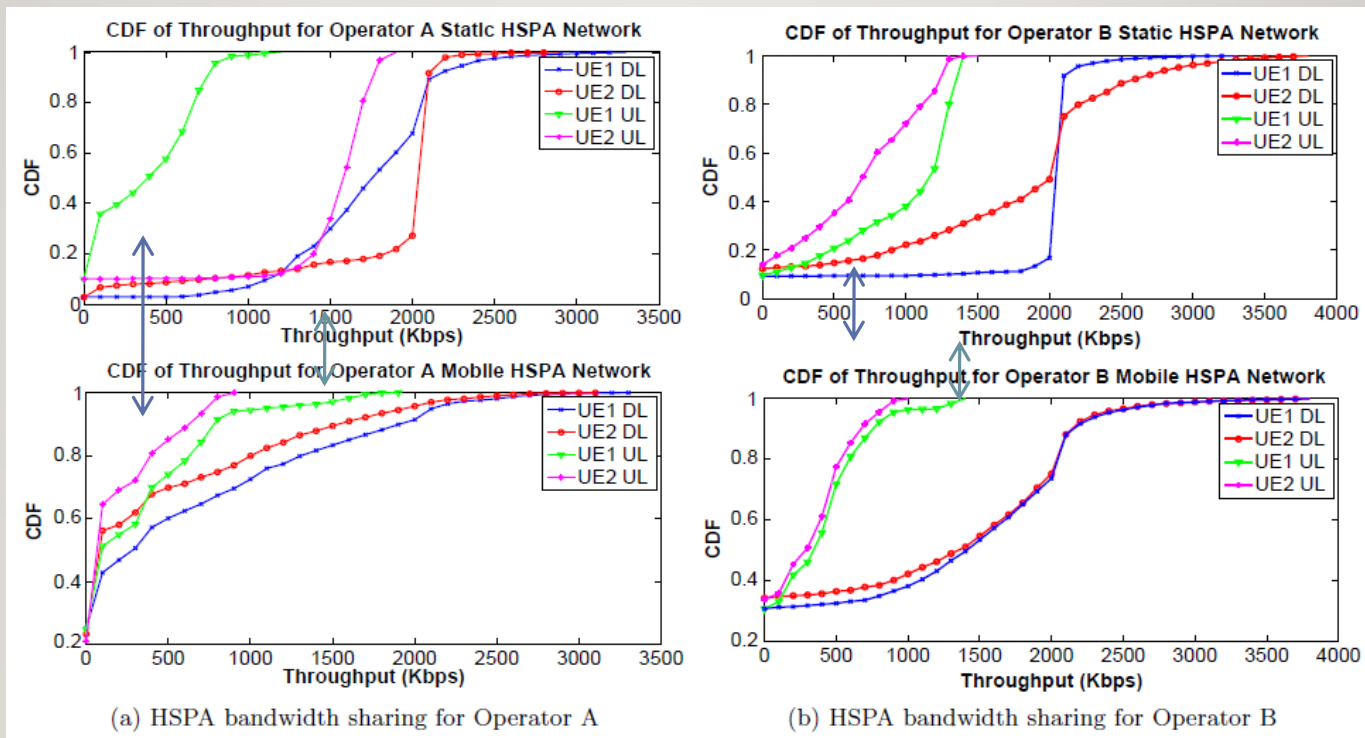

# BANDWIDTH SHARING AMONG USERS

MobiHoc '10

---

- UE can hardly keep its dominance under rapid change of radio environment.
  - Mobile nodes may see better signal quality at new locations
- Cell to cell based scheduling algorithm prevent unfairness from propagating

# CONTEXT

MobiHoc '10

---

*Common View: Mobility affects all flows equally. And TCP flows suffer more than UDP ones*

Observation: TCP flows unexpectedly see much better performance during mobility than UDP flows.

# BANDWIDTH SHARING AMONG TRAFFIC FLOWS

MobiHoc '10

- TCP flows see better performance during mobility

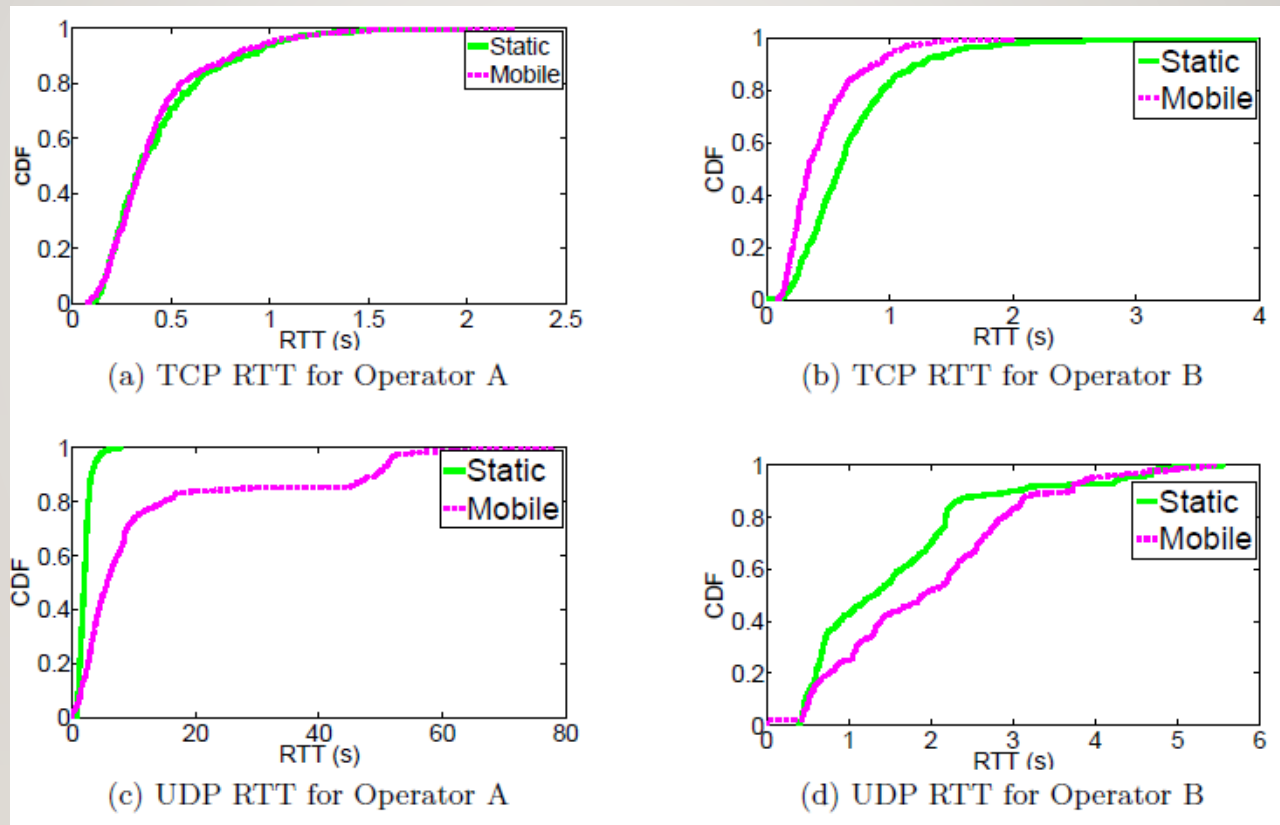

# BANDWIDTH SHARING AMONG TRAFFIC FLOWS

MobiHoc '10

- TCP traffic is much constrained and adaptive to the channel condition, while UDP traffic keeps pumping almost the same amount of data regardless of the channel condition

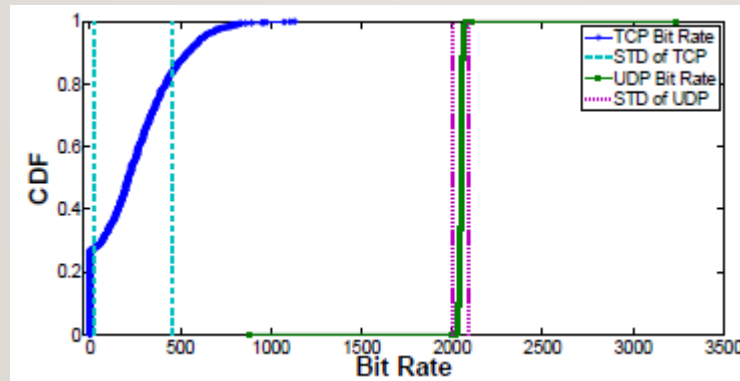

# CONTEXT

MobiHoc '10

---

*Common View: Handoffs are triggered in the transitional region between cells and always result in a better wireless connection*

Observation: Nearly 30% of all handoffs, selection of a base station with poorer signal quality can be witnessed

# MOBILITY IMPACT IN TRANSITIONAL REGIONS

MobiHoc '10

- throughput often drops sharply, and sometimes, as high as 90% during handoff period.

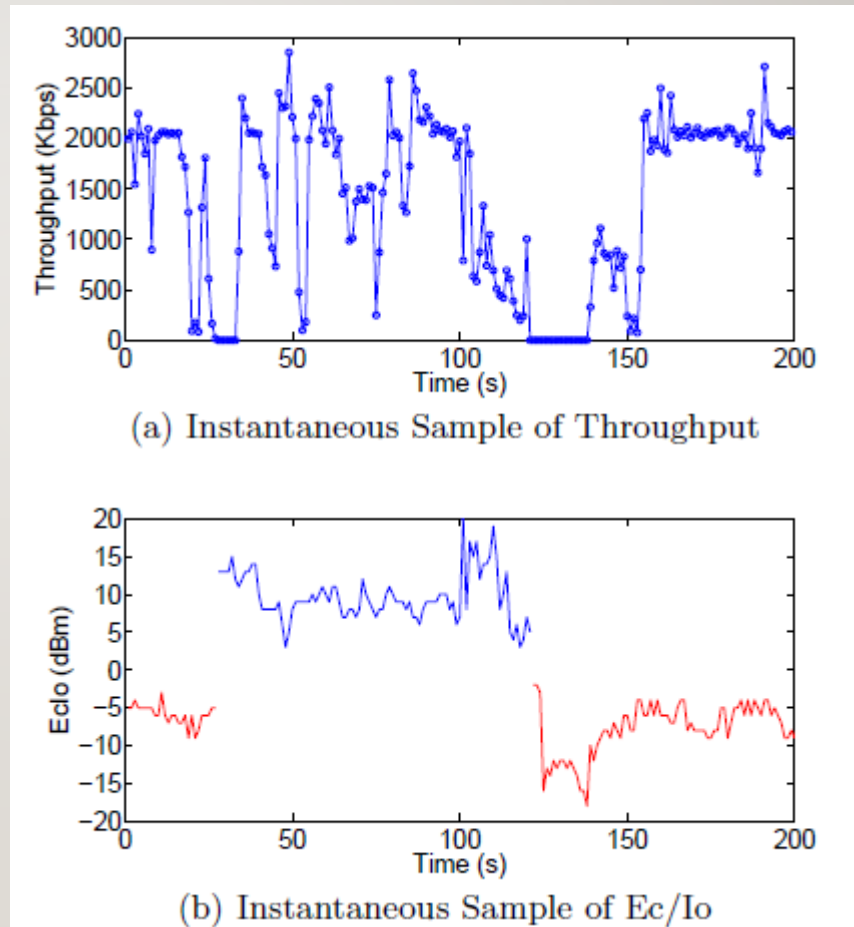



# MOBILITY IMPACT IN TRANSITIONAL REGIONS

MobiHoc '10

- $E_c/I_0$  of the new base stations are statistically better than the original base stations by 10dBm.
- But almost 30% of all the handoffs do not end up with a better base stations

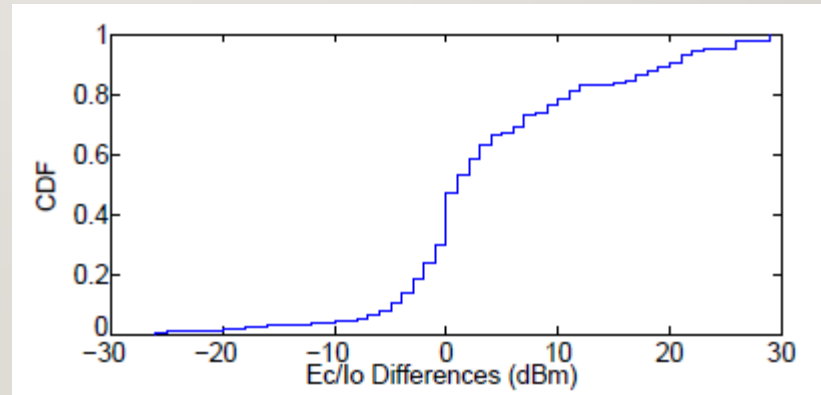
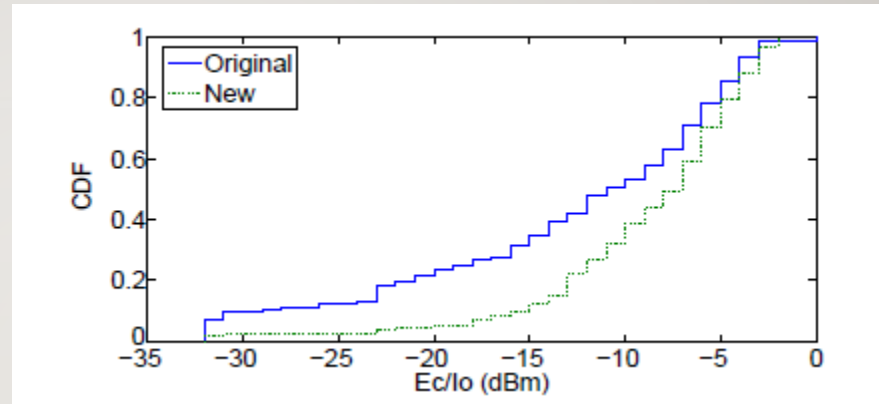

# CONCLUSION

MobiHoc '10

---

- Mobility is a double edged sword
  - Degrades HSPA services, e.g. throughput
  - Improves fairness in bandwidth allocation among users and traffic flows
- Communication characteristics in HSPA transitional regions are very complicated

# ADDITIONAL ACKNOWLEDGEMENTS

---

- Part of the slides are adapted from the slides of Posco Tso, Harish Vishwanath, Erran Li and Justino Lorenzo, Saro Velrajan and TCL India
- Tso, et al, “Mobility: A Double-Edged Sword for HSPA Networks”, MobiHoc’10, September 20–24, 2010, Chicago, Illinois, USA.
  - [http://web.cse.ohio-state.edu/~xuan.3/papers/10\\_mobihoc\\_ttjx.pdf](http://web.cse.ohio-state.edu/~xuan.3/papers/10_mobihoc_ttjx.pdf)