

# first year: Wood Fabrication Project

## A volume of cubic space: Step One

|                  |   |
|------------------|---|
| Issued           | Wednesday, September 12, 2007   |
| Objective        | This semester's project will be directly linked to the studio concepts learned throughout the semester. Ideas such as volume, implied spatial definition, hierarchy, cartesian axes, primary/ secondary spaces, composition, proportion, consistency and articulation will be explored in the development of a cubic volume of space.   |
| Working Process: | <p>As part of your process you are to produce sketches, study models and mock-ups of all your potential design elements before you will be able to work in the shop. Expect to provide adequate forms of representation to the shop directors and monitors before starting any part of the fabrication process. Each Wednesday you will show your studio instructors how you will develop your cubic volume of space. Each design decision will be based on the skills you are learning in the shop demonstrations as well as the studio projects you are working on in the studio. This project is meant to feed off of your studio learning.</p> <p>You will be asked to make a cubic volume using a rough sawn poplar wood blank and your 2x4 supplied in project 4. These basic materials will evolve throughout the semester into a spatial cubic volume while also providing an interior series of spaces implied by cartesian planes, orthographic cuts, planar reliefs and circular subtractions.</p> |
| Step One:        | The first step in your process will be to build an 18" x 18" x 6" frame (see the provided drawing attached). Conceptually you should consider this the physical context which all the actions that follow will rely on. Your later additions will respond to this context in a variety of ways. As you began to make decisions about your design, each step will further reinforce the spatiality of the cubic volume and the implied spaces within it.   |
| Due              | Wednesday, September 26, 2007 @ 1.30 p.m.   |

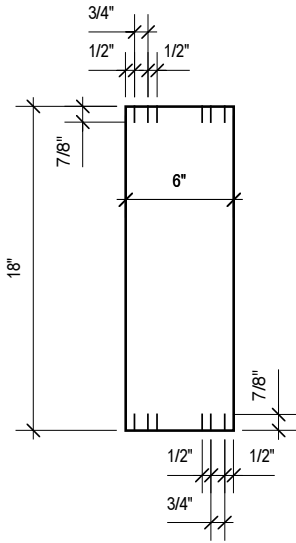

A: FIRST CUTS INTO  
PLANK  
(2) REQUIRED

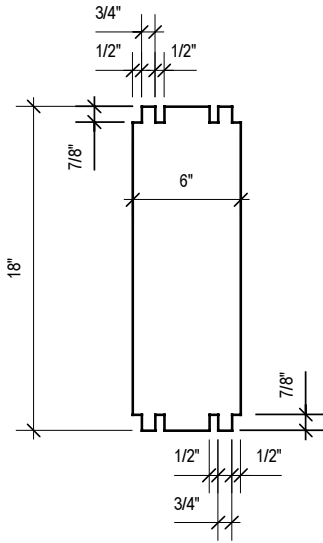

B: FIRST FINGER JOINT  
PATTERN  
(2) REQUIRED

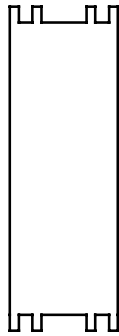

C: TRANSFER PART B  
ONTO THE OTHER TWO  
PIECES AND CUT  
(2) REQUIRED

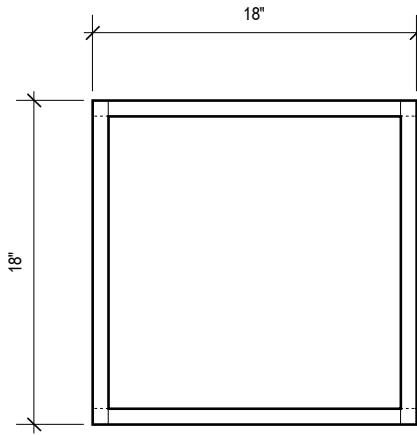

D: FRICTION FIT OF ALL (4) FOUR  
SURFACES  
SIDE VIEW OR TOP VIEW

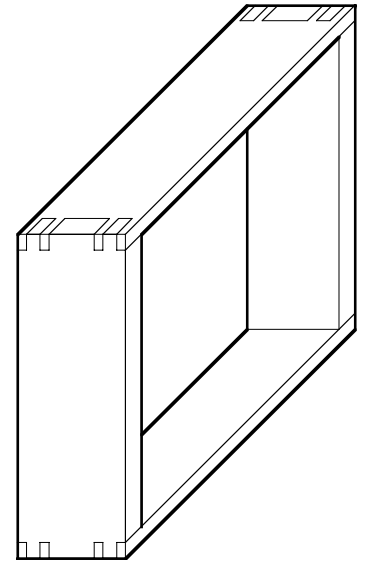

STEP ONE: PARALINE DRAWING OF THE  
COMPLETE ASSEMBLY