

first year: wood fabrication project

A volume of cubic space: Step Three

Reference steps one and two for more information

Issued	Monday, October 22, 2007
Objective	This part of the project introduces you to how relief (milling) and notching can help to define the internal spaces within the 18" x 18" x 18" cube of space. In addition, you are to compose a minimum of one (maximum of 2) spherical and/ or cylindrical implied volumes of space within the overall composition.
Working Process	<p>For this part of the shop project, you are to incorporate relief (milling) and notching in your design to help define the (1) major and (3) minor spaces within your cube. Spatial articulation involves understanding the relationship of the planes in concert with the reliefs (milling) and notching of the spatial volume. It is the objective of milling and notching of the wood surfaces to define the volumes. Randomly placed reliefs (milling) or notching should be avoided. Instead, relief (milling) and notching of the internal planes and frame should be added to define the (4) internal volumes' edges and corners.</p> <ul style="list-style-type: none">• Notches and milling must be simple rectangles with all edges parallel and perpendicular to the sides of the cube.• Modify your cardboard study model to demonstrate how you can use milling and relief to define the internal spaces.• Modify your cardboard study model to introduce spherical and/ or cylindrical implied volumes of space (1 min., 2 max.)• All spherical and/ or cylindrical implied volumes are to a minimum of 1 1/2" in diameter. <p>See the included diagrams and drawings for more information.</p>
Ongoing / Process	<ul style="list-style-type: none">• Continue to resolve your partitioning with cardboard using the box itself.• Mill the remaining pine from the 2x4s into 1/2" and 1/4" thick pieces.• Layout the 1/2" and 1/4" dados/slots/mortises on your extensions (and box sides) and cut them.• Cut up your 1/2" and 1/4" plywood with the band saw or table saw (and notch for half laps) with band saw, and also cut dados/ slots/mortises as required.
Deadlines	<p>Wednesday, October 24, 2007 @ 1.30 p.m.</p> <ul style="list-style-type: none">• You MUST have your pine 3/4" extensions installed and notched as your design requires. <p>Wednesday, October 31, 2007 @ 1.30 p.m</p> <ul style="list-style-type: none">• You MUST have substantially cut all your planes out of the real materials and they should be installed into the box. <p>Wednesday, November 7, 2007 @ 1.30 p.m.</p> <ul style="list-style-type: none">• You are to have everything substantially completed including circular/ spherical cutouts as well as any further articulation by notching and milling. <p>Monday, November 19, 2007 @ 10.00 p.m. Project with finishes due.</p>

PLEASE NOTE: THE OBJECTIVE OF NOTCHING AND MILLING IS TO ADD SPATIAL DEFINITION TO THE (1) MAJOR AND (3) MINOR SPACES YOU ARE DEFINING. ONE SHOULD AVOID RANDOM NOTCHING AND RELIEF.

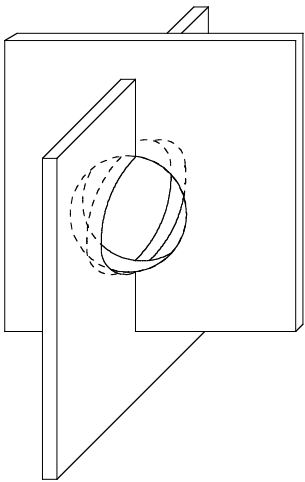

EXAMPLE 4A:
IMPLIED SPHERICAL SPACE

(1 1/2" MIN. DIAMETER HOLES)

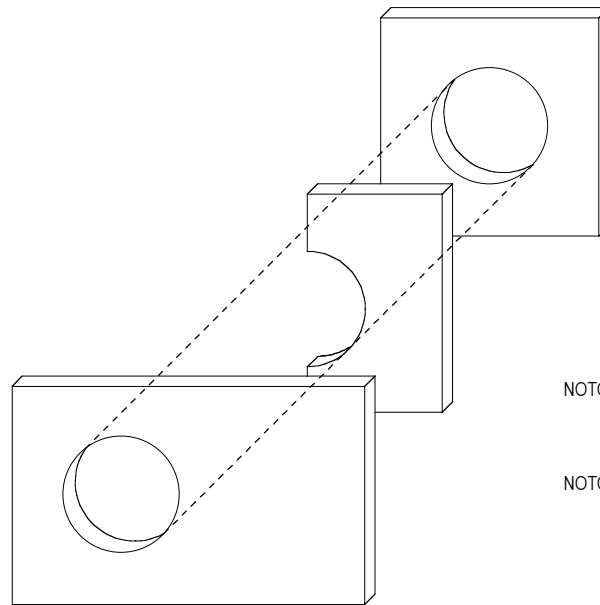

EXAMPLE 4B:
IMPLIED CYLINDRICAL SPACE

(1 1/2" MIN. DIAMETER HOLES)

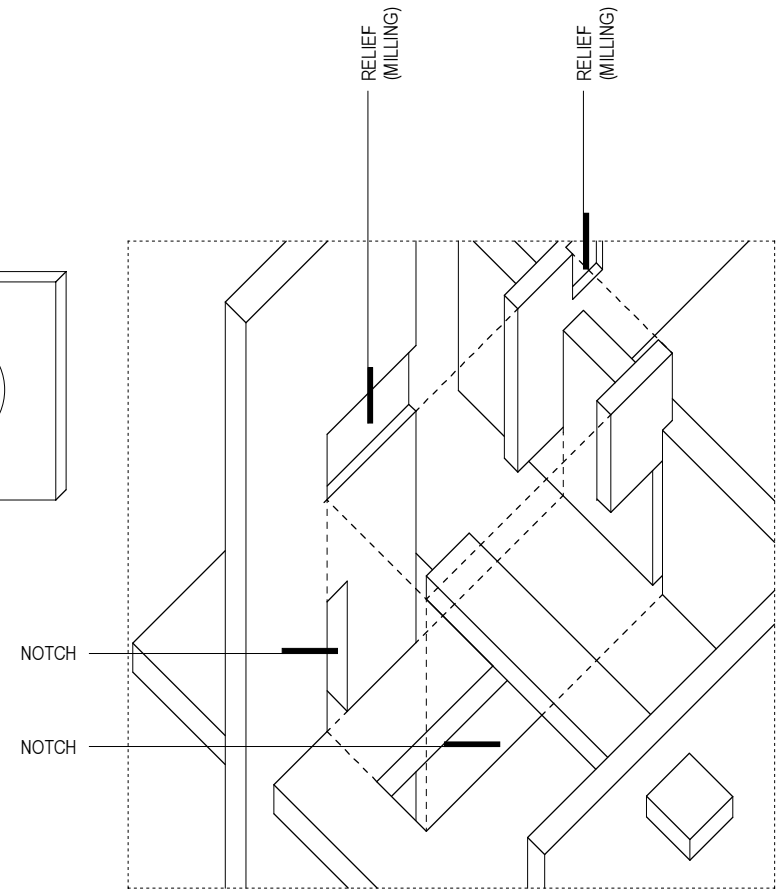

EXAMPLE 5:
SPATIAL DEFINITION USING PLANES, NOTCHING AND RELIEF (MILLING)

NOTE HOW EDGES HELP TO DEFINE THE SPACE.

YOUR COMPOSITION IS TO INCLUDE A MINIMUM OF ONE
OR A MAXIMUM OF 2 SPHERICAL AND/ OR CYLINDRICAL
IMPLIED VOLUMES OF SPACE